

# G7A

## Hardware User Guide

Issue 1.2 Date 2019-08-15



**Copyright © Neoway Technology Co., Ltd 2019. All rights reserved.**

No part of this document may be reproduced or transmitted in any form or by any means without prior written consent of Neoway Technology Co., Ltd.

neoway 有方 is the trademark of Neoway Technology Co., Ltd.

All other trademarks and trade names mentioned in this document are the property of their respective holders.

**Notice**

This document provides guide for users to use G7A.

This document is intended for system engineers (SEs), development engineers, and test engineers.

THIS GUIDE PROVIDES INSTRUCTIONS FOR CUSTOMERS TO DESIGN THEIR APPLICATIONS. PLEASE FOLLOW THE RULES AND PARAMETERS IN THIS GUIDE TO DESIGN AND COMMISSION. NEOWAY WILL NOT TAKE ANY RESPONSIBILITY OF BODILY HURT OR ASSET LOSS CAUSED BY IMPROPER OPERATIONS.

THE INFORMATION IN THIS DOCUMENT IS SUBJECT TO CHANGE WITHOUT NOTICE DUE TO PRODUCT VERSION UPDATE OR OTHER REASONS.

EVERY EFFORT HAS BEEN MADE IN PREPARATION OF THIS DOCUMENT TO ENSURE ACCURACY OF THE CONTENTS, BUT ALL STATEMENTS, INFORMATION, AND RECOMMENDATIONS IN THIS DOCUMENT DO NOT CONSTITUTE A WARRANTY OF ANY KIND, EXPRESS OR IMPLIED.

Neoway provides customers complete technical support. If you have any question, please contact your account manager or email to the following email addresses:

Sales@neoway.com

Support@neoway.com

**Website:** <http://www.neoway.com>

# Contents

<b>1 About G7A</b> .....	<b>1</b>
1.1 Overview .....	1
1.2 Block Diagram .....	1
1.3 Specifications .....	2
<b>2 Pad Layout and Pin Definition</b> .....	<b>4</b>
2.1 Pad Layout .....	4
2.2 Pin Definition .....	5
<b>3 Application Interfaces</b> .....	<b>7</b>
3.1 Power Supply .....	7
3.1.1 VBAT .....	7
3.1.2 VDD_IO .....	7
3.1.3 VBACKUP .....	7
3.1.4 Work Modes .....	8
3.1 RESET_N .....	8
3.2 UART .....	10
3.3 1PPS .....	10
3.4 ANT_ON .....	11
<b>4 Antenna Interface</b> .....	<b>12</b>
4.1 Impedance Control .....	12
4.2 Reference Design of Active GNSS Antenna .....	14
4.3 Recommended Antenna .....	16
<b>5 Electrical Feature and Reliability</b> .....	<b>17</b>
5.1 Electrical Features .....	17
5.2 Temperature .....	18
5.3 ESD Protection .....	18
<b>6 Mechanical Features</b> .....	<b>19</b>
6.1 Dimensions .....	19
6.2 Label .....	20
6.3 Packaging .....	20
6.3.1 Tape & Reel Packaging .....	20
6.3.2 Moisture-Sensitive .....	22
<b>7 Application Design and SMT</b> .....	<b>23</b>
7.1 G7A Foot Print .....	23
7.2 Recommended Footprint .....	23
7.3 Stencil .....	24
7.4 Solder Paste .....	24
7.5 Reflow Profile .....	24
<b>8 Safety Recommendations</b> .....	<b>26</b>

---

A Abbreviation..... 27

Neoway Confidential

## Table of Figures

Figure 1-1 Block diagram .....	2
Figure 2-1 G7A pin definition (top view).....	4
Figure 3-1 Reset controlled by button .....	9
Figure 3-2 Reset circuit with triode separating.....	9
Figure 3-3 Reset timing of G7A.....	9
Figure 3-4 UART connection.....	10
Figure 3-5 1PPS timing .....	11
Figure 4-1 Internal circuit .....	12
Figure 4-2 L network .....	13
Figure 4-3 T network .....	13
Figure 4-4 Pi network .....	13
Figure 4-5 Recommended RF PCB design .....	14
Figure 4-6 Reference design of active antenna (with control) .....	15
Figure 4-7 Reference design of active antenna (without control) .....	15
Figure 6-1 G7A dimensions (Unit: mm) .....	19
Figure 6-2 G7A-B1 label .....	20
Figure 6-3 G7A-D1 label .....	20
Figure 7-1 G7A foot print (bottom view).....	23
Figure 7-2 Recommended PCB footprint (top view) .....	24
Figure 7-3 Temperature curve.....	25

## Table of Tables

Table 1-1 Versions and bands.....	1
Table 2-1 IO types .....	5
Table 2-2 Pin definition.....	5
Table 3-1 Power status, clock status, and current in different work modes.....	8
Table 4-1 Recommended antenna for G7A .....	16
Table 5-1 Extreme operating voltage .....	17
Table 5-2 Recommended operating voltage .....	17
Table 5-3 Current features .....	17
Table 5-4 Temperature feature.....	18
Table 5-5 ESD feature.....	18

# About This Document

## Scope

This document is applicable to G7A series.

It defines the features, indicators, and test standards of the G7A module and provides reference for the hardware design of each interface.



## Audience

This document is intended for [system engineers \(SEs\)](#), [development engineers](#), and [test engineers](#).

## Change History

Issue	Date	Change	Changed By
1.0	2019-02	Initial draft	Zhuo Jianzheng
1.1	2019-07	<ul style="list-style-type: none"><li>Deleted I2C</li><li>Updated the bottom dimensions</li></ul>	Gong Hualiang
1.2	2019-08	<ul style="list-style-type: none"><li>Revised the values of channel quality</li><li>Reversed the label figures</li></ul>	Gong Hualiang

## Conventions

Symbol	Indication
	This warning symbol means danger. You are in a situation that could cause fatal device damage or even bodily damage.
	Means reader be careful. In this situation, you might perform an action that could result in module or product damages.
	Means note or tips for readers to use the module

## Related Documents

*Neoway\_G7A\_Datasheet*

*Neoway\_G7A\_Product\_Specifications*

*Neoway\_G2/G7A\_Receiver\_Command\_Manual*

*Neoway\_GNSS\_EVK\_User\_Guide*

Neoway Confidential

# 1 About G7A

G7A is a GNSS module that supports BDS B1, GPS L1, and GLONASS L1. It adopts a unified chipset integrating baseband and RF and its dimensions are 10.6 mm x 9.7 mm x 2.2 mm. It is an optimal navigation solution to demands for high sensitivity, low power consumption, and low cost in different navigation devices

## 1.1 Overview

G7A series including the following variants and band configurations.

Table 1-1 Versions and bands

Module	Variants	GPS	BDS	GLONASS	Support GAGAN
G7A	G7A-B1	√	√		
	G7A-D1	√		√	√

## 1.2 Block Diagram

G7A consists of the following functional units:

- GNSS baseband
- RF front end components
- RTC
- Peripheral interfaces

Figure 1-1 Block diagram

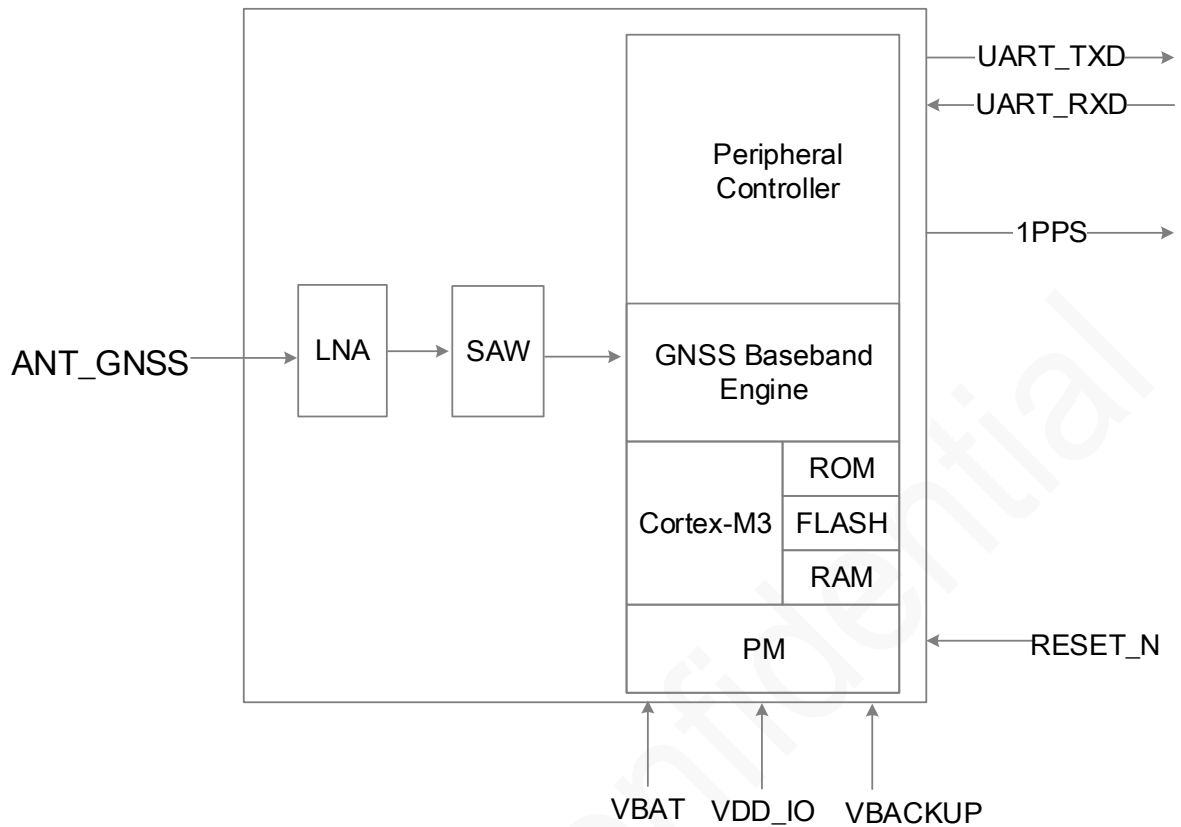

### 1.3 Specifications

Parameter	Description	Min.	Typ.	Max	Unit	Remarks
Positioning precision (open air)	Horizontal		<3		m	
	Elevation		<4.5		m	
Speed precision			<0.1		m/s	
Channel quantity	Capturing		32			
	Tracking		32			
TTFF (@-130dBm)	Cold start		<32		s	
	Hot start		1		s	
	Recapture		1		s	
Sensitivity	Cold start		-148		dBm	
	Hot start		-156		dBm	
	Recapture		-160		dBm	
	Tracking		-162		dBm	

Baud rate		4800	9600	256000	bps	9600bps default	by
Update frequency			1	10	Hz	1Hz by default	
Operating voltage	VBAT	2.7	3.3	3.6	V		
	VDD_IO	2.7	3.3	3.6	V		
	VBACKUP	1.4	3.3/3.0	3.6	V		
Current (@instrument)	Capturing		30		mA	3.3 V	
	Tracking		28		mA	3.3 V	
	Idle		10		μA	3.3 V	
Certification Approvals	and	RoHS, CE					

## 2 Pad Layout and Pin Definition

There are 18 pins on G7A and their pads are in LCC package.

### 2.1 Pad Layout

错误!未找到引用源。 shows the pad layout of G7A.

Figure 2-1 G7A pin definition (top view)

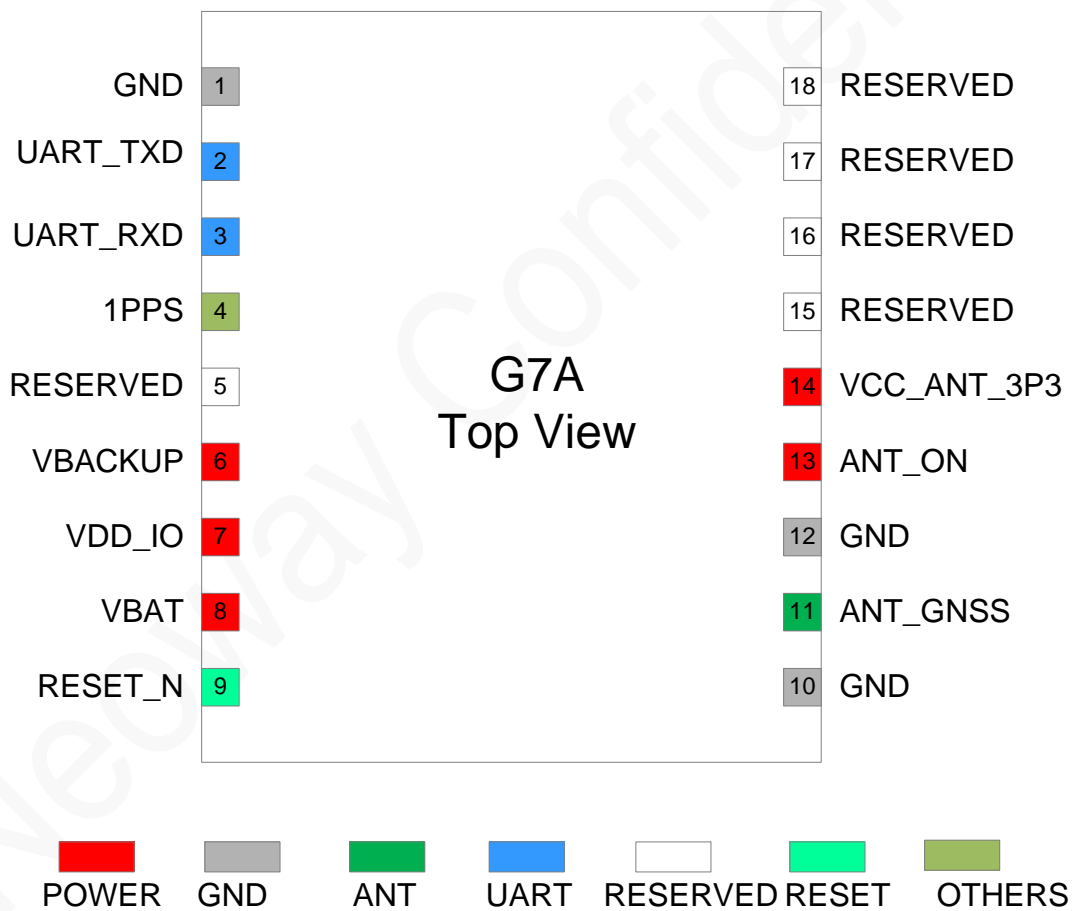

## 2.2 Pin Definition

Table 2-1 lists the IO types

Table 2-1 IO types

IO types	
B	Digital input/output, COMS logic level
DO	Digital output, COMS logic level
DI	Digital input, COMS logic level
PO	Power output
PI	Power input
AO	Analog output
AI	Analog input
DC feature description	
P1	Power type of digital IO interface
	3.3V: V <sub>IH</sub> =2.4V~3.6V, V <sub>IL</sub> = -0.3V~0.6V V <sub>OH</sub> =2.9V~3.3V, V <sub>OL</sub> =0V~0.4V

Table 2-2 Pin definition

Signal	Pin	I/O	Function	DC Feature	Remarks
<b>Power</b>					
VBAT	8	PI	Main power supply	2.7V~3.6V (Typ:3.3V)	Supply a maximum current of 100 mA
VDD_IO	7	PI	IO power input	2.7V~3.6V (Typ:3.3V)	Supply power for digital IO. Connect it to VBAT
VBACKUP	6	PI	Backup power supply input	1.4V~3.6V (Typ:3.3/3.0V) I <sub>norm</sub> =10μA	Supply power to RTC and backup RAM. Leave it floating if not used.
VCC_ANT_3P3	14	PO	Power supply for external RF component	Same as that of VBAT	Leave it floating if not used
GND	1, 10, 12				Ensure that all GND pins are grounded.
<b>Control interface</b>					
RESET_N	9	DI	Reset the module	P1	Low level triggered

					Leave it floating if not used.
<b>RF</b>					
ANT_GNSS	11	AI	RF signal input		See chapter 4.
<b>UART</b>					
UART_TXD	2	DO	Data transmitting	P1	Used for data transmission.
UART_RXD	3	DI	Data receiving	P1	Leave it floating if not used.
<b>Others</b>					
ANT_ON	13	DO	Switch external LNA or antenna	3.3V output	Output low level in idle mode Leave it floating if not used
1PPS	4	DO	Pulse per second	P1	Pulled up by default. Leave it floating if not used.
RESERVED	5, 15, 16, 17, 18		Reserved pins		Leave them floating if not used.

## 3 Application Interfaces

G7A provides power supply interface, UART interface, I2C interface, and 1PPS interface.

This chapter describes how to use each interface and the design precautions.

### 3.1 Power Supply

Signal	Pin	I/O	Function	Remarks
VBAT	8	PI	Main power supply	2.7 V to 3.6 V (Typ:3.3 V)
VDD_IO	7	PI	IO power input	2.7 V to 3.6 V (Typ:3.3 V)
VBACKUP	6	PI	Backup power supply	1.4 V to 3.6 V (Typ:3.3/3.0 V) Supply power to RTC and backup RAM. Leave it floating if not used.
VCC_ANT_3P3	14	PO	Power supply for external RF component	Same as that of VBAT
GND	1, 10, 12			Ensure that all GND pins are grounded.

#### 3.1.1 VBAT

VBAT is the power supply input pin of the module. Its input voltage ranges from 2.7 V to 3.6V and the typical value is 3.3 V. In addition to baseband, it supplies power to RF component. The performance of the VBAT power supply is a critical path to module's performance and stability.

To ensure the optimal performance of the module, use low-noise LDO specifically for RF to supply power.

#### 3.1.2 VDD\_IO

VDD\_IO is the power supply for digital IO of the module. It is recommended to connect it to VBAT in your applications.

#### 3.1.3 VBACKUP

VBACKUP is the backup power supply of the module. It is used to supply power to RTC and backup RAM after VBAT is shut down so that the module can save key ephemeris data and almanac for hot start, warm start, and ephemeris computation.

The input voltage of the backup power supply ranges from 1.4 V to 3.6 V. The recommended value is 3.3/3.0V. It can be connected to a button battery or capacitor.

### 3.1.4 Work Modes

G7A supports the following two work modes:

- Positioning mode

In positioning mode, the capturing engine is enabled all the time and it will automatically switch to tracking status to decrease operating current after finding valid location information, all ephemeris and data.

- Idle mode

The module enters idle mode after VBAT is shut down. Only RTC backup part works normally. The power and clocks of all other functions are shut down.

After VBAT is supplied power, the module enters positioning mode.

To support hot start and warm start, VBACKUP must be able to supply power after VBAT is shut down.

To position quickly, keep the power supply of the VBACKUP.

Table 3-1 lists the power status, clock status, and current in different modes.

Table 3-1 Power status, clock status, and current in different work modes

Work Mode	VBAT	VBACKUP	Main Clock	RTC Clock	Current
Positioning	ON	ON	ON	ON	$I_{VBAT} + I_{VDD\_IO}$ 30mA @multi-mode
Idle	OFF	ON	OFF	ON	$I_{VBACKUP} = 20\mu A$

## 3.1 RESET\_N

RESET\_N is triggered by negative pulse that exceeds 160 ms. This pin is pulled up internally and its typical high-level voltage is 3.3 V. Leave this pin floating if you do not use it.

If you use an IO system other than 3.3 V, it is recommended to add a triode to separate it. Refer to the following designs. To reset the module through high level, refer to Figure 3-2.

Figure 3-1 Reset controlled by button

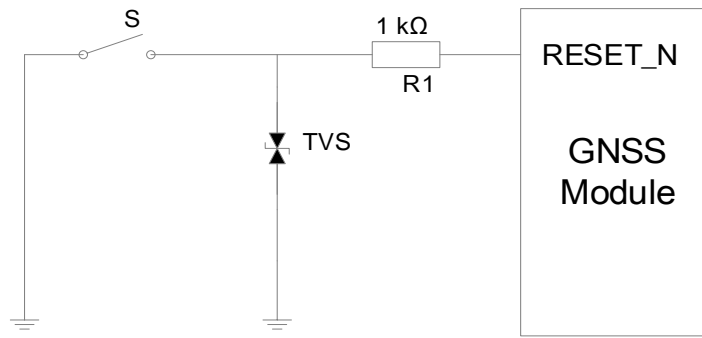

Figure 3-2 Reset circuit with triode separating

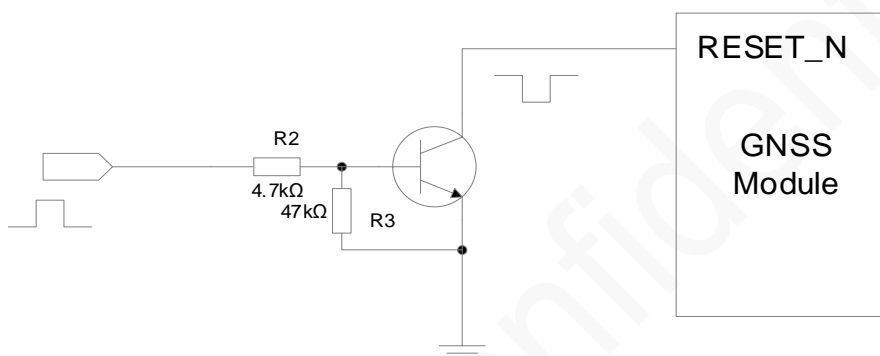
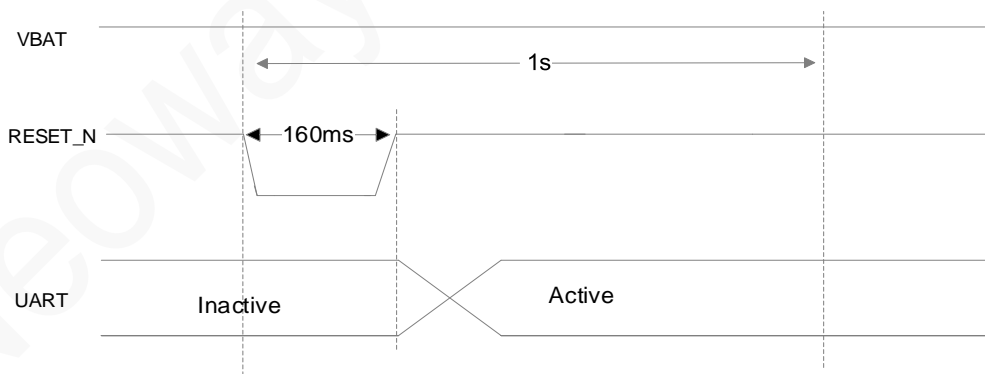

Figure 3-3 shows the reset timing of G7.

Figure 3-3 Reset timing of G7A



### 3.2 UART

Signal	Pin	I/O	Function	Remarks
UART_TXD	2	DO	Data transmitting	
UART_RXD	3	DI	Data receiving	

UART outputs NMEA data at UTC second boundary. The MCU can switch the work mode, set baud rate, and select UART through AT commands. The module supports baud rate ranging from 4800bps to 2560400 bps. The default baud rate is 9600bps. Data format: 1 start bit, 8 data bits, 1 stop bit, no checksum bit.

For more information, see *Neoway\_G2/G7A\_Receiver\_Commands\_Manual*.

Figure 3-4 shows the connection of the UART interface. If the logic level of UART and MCU does not match, add a level shifter.

Figure 3-4 UART connection

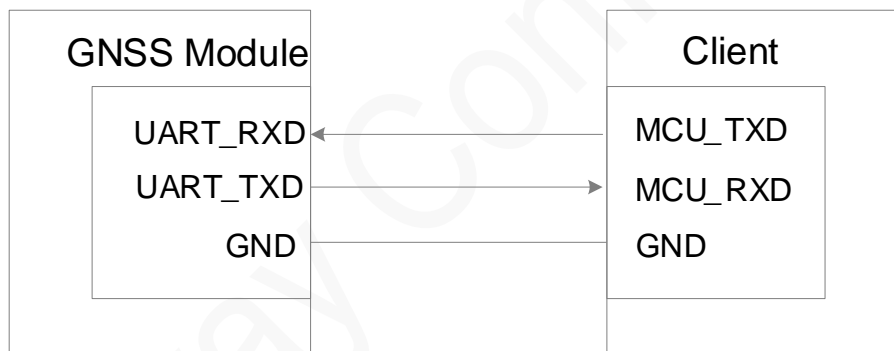

### 3.3 1PPS

1PPS signal is output several seconds after the module fixes position.

Figure 3-5 shows the timing of 1PPS signal.

Figure 3-5 1PPS timing

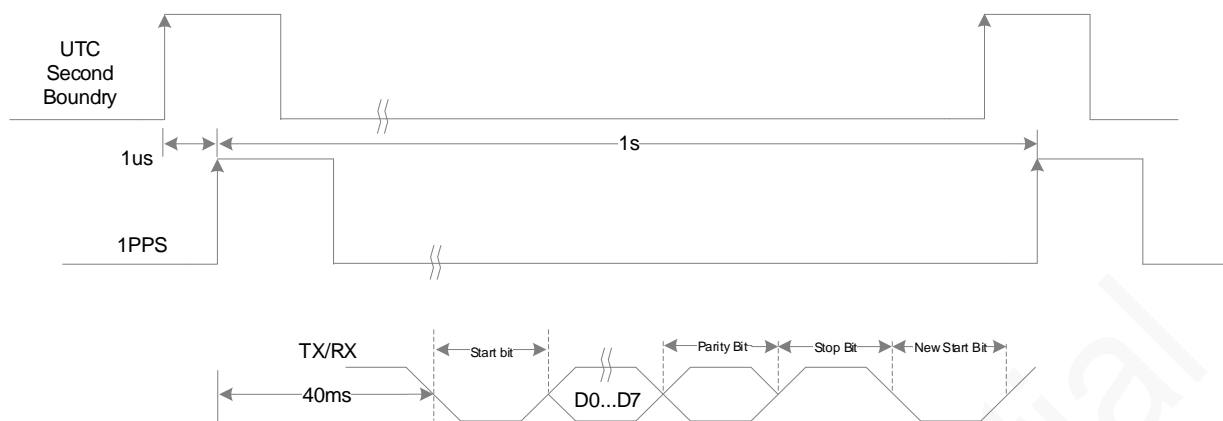

### 3.4 ANT\_ON

In positioning mode, ANT\_ON outputs 3.3 V. It is used to switch the external LNA or antenna.

In sleep or standby mode, it outputs low level. For details about the reference design, see 4.2.

## 4 Antenna Interface

G7A provides one antenna interface for GNSS. This chapter describes how to control the impedance in design and provides reference designs with antenna and recommended antenna specifications.

### 4.1 Impedance Control

ANT\_GNSS is the GNSS RF interface of G7A, which requires a characteristic impedance of 50  $\Omega$ . Figure 4-1 shows the structure inside G7A.

Figure 4-1 Internal circuit

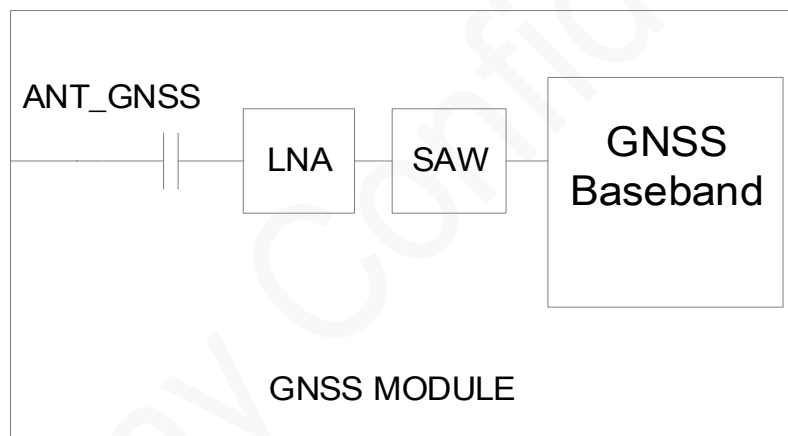

Control the impedance of the traces between the pins and antenna to ensure the RF performance. An impedance matching circuit, such as L network, T network, and pi network is mandatory in between. Pi network is recommended.

Figure 4-2 L network

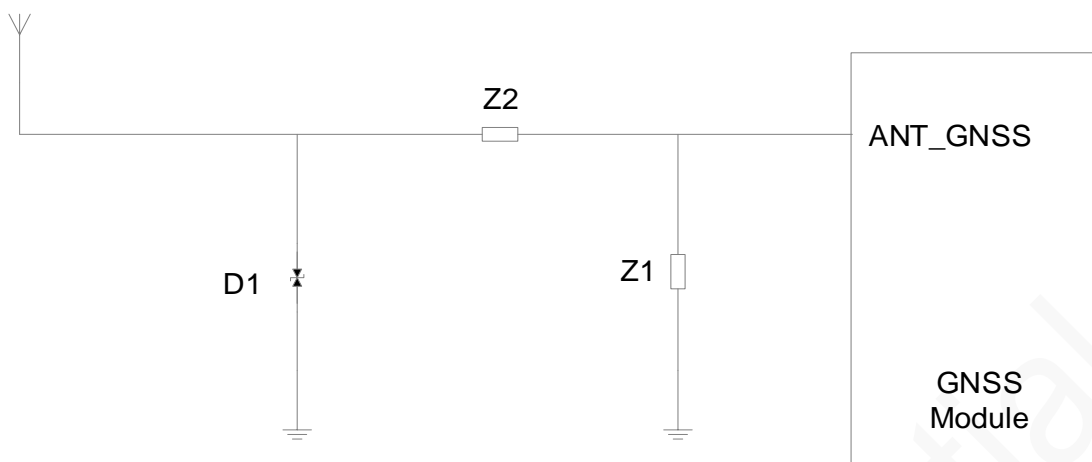

Figure 4-3 T network

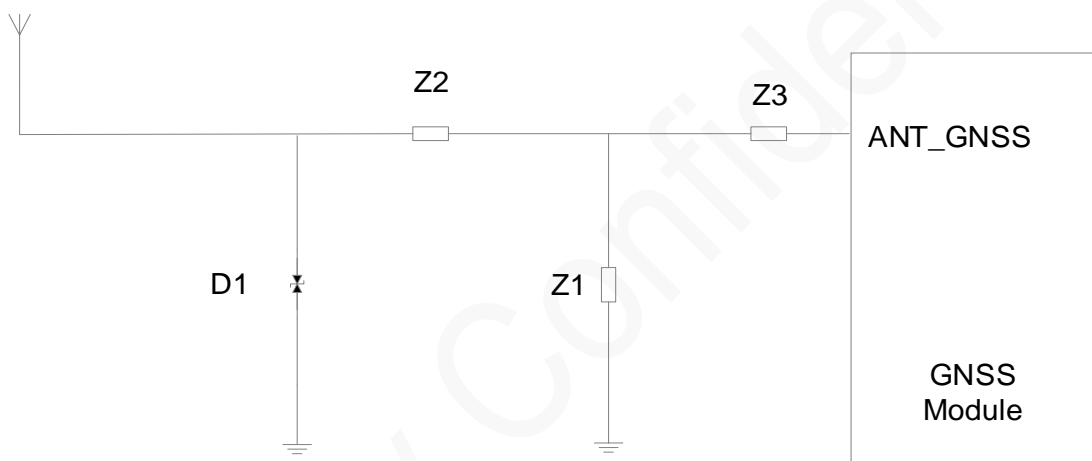
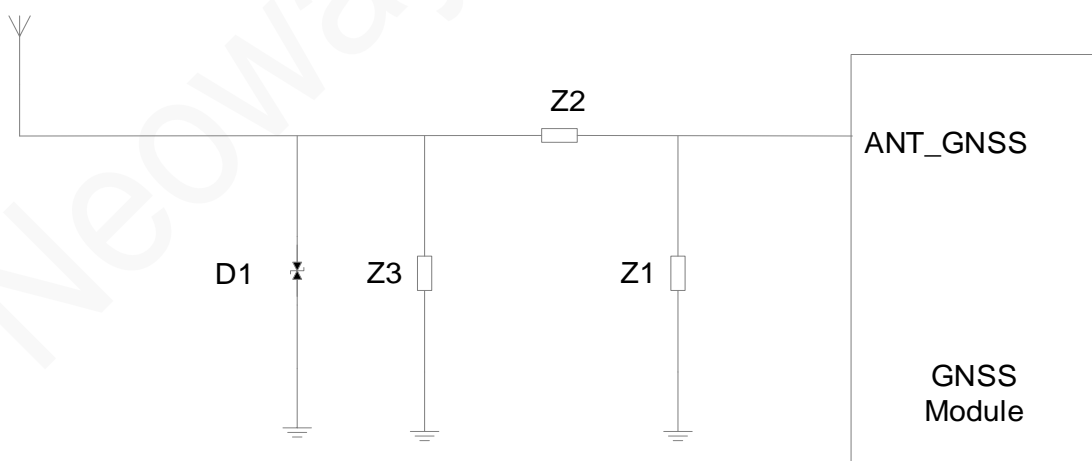

Figure 4-4 Pi network



Schematic Design Guidelines:

- Element components in the above figures are capacitors, inductors, and  $0\ \Omega$  resistors. Place these RLC components as close to the antenna interface as possible.
- Add an ESD protector if the antenna might generate static electricity. The protector can be a TVS diode with a junction capacitance of lower than  $0.5\ \text{pF}$ . Ensure that the reverse breakdown voltage of the TVS is greater than  $10\ \text{V}$  (above  $15\ \text{V}$  is recommended).
- G7A embeds an LNA, and no external LNA is required if a passive GNSS antenna is used.

PCB Layout Guidelines:

- Lay copper foil around RF connector. Dig as many ground holes as possible on the copper to ensure lowest grounding impedance.
- The trace between G7A and the antenna connector, should be as short as possible. Control the trace impedance to  $50\ \Omega$ .
- If customers adopt SMA connector, big RF solder pad might result in great parasitic capacitance, which will affect the antenna performance. Remove the copper on the first and second layers under the RF solder pad.

Figure 4-5 Recommended RF PCB design

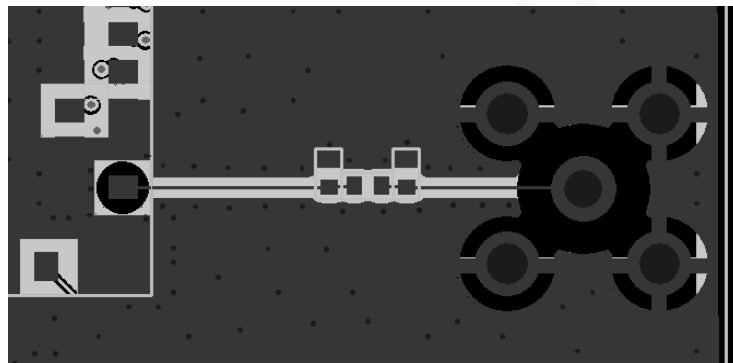

- On the PCB, keep the RF signals and components far away from digital circuits, power supplies, transformers, great inductors, the clock circuit, etc.

## 4.2 Reference Design of Active GNSS Antenna

After the antenna receives GNSS satellite signals, the LNA amplifies the signals and then transmits them to the ANT\_GNSS through feeder and PCB traces. Figure 4-6 and Figure 4-7 shows reference designs of active GNSS antenna.

Figure 4-6 Reference design of active antenna (with control)

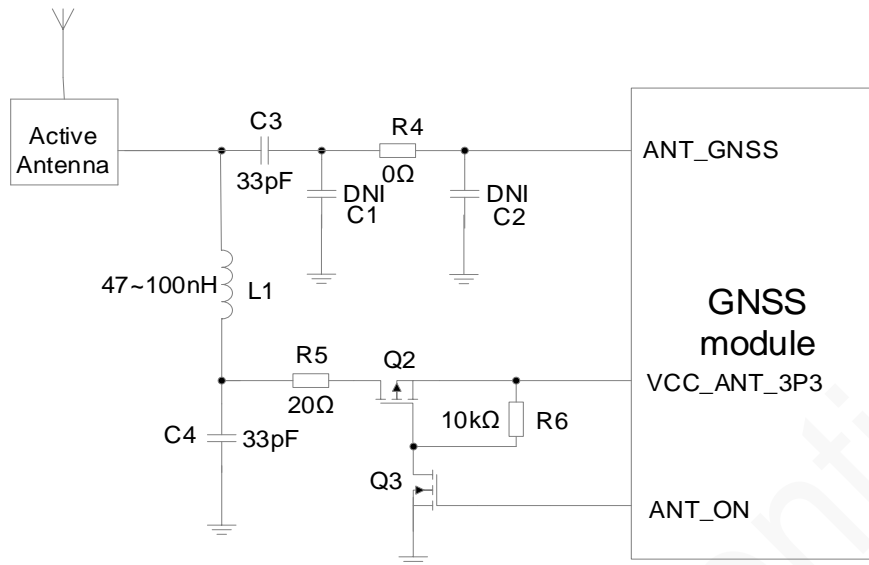
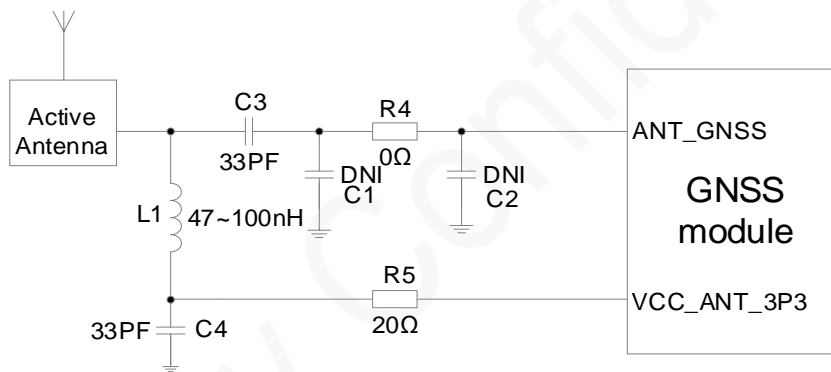

Figure 4-7 Reference design of active antenna (without control)



Schematic Design Guidelines:

- For matching circuit design between GNSS interface and antenna, refer to design guidelines in 4.1.
- If there is a requirement for power consumption in the application, connect an active antenna with control.

In position fix mode, ANT\_ON outputs high level, Q2 and Q3 are switched on simultaneously, and VCC\_ANT\_3P3 supplies power for the active antenna.

In sleep or standby mode, ANT\_ON outputs low level, Q2 and Q3 are switched off, and the power for active antenna is shut down.

This design will help reduce the power consumption of G7A.

PCB Layout Guidelines:

- For guidelines of PCB layout between GNSS interface and antenna, refer to layout guidelines in 4.1.

- 50Ω impedance is required for the feeder and PCB traces and the traces should be as short as possible. The power supply of the active antenna is fed by the 47 to 100 nH inductor through the signal traces.
- Keep GNSS antenna circuit far away from the communications antenna circuits on PCB. Otherwise, these two parts will jam each other, lowering the RF performance.

## 4.3 Recommended Antenna

Table 4-1 Recommended antenna for G7A

Antenna Type	Parameter	Value	Remarks
Passive antenna	Frequency	GPS:1575.42 MHz BDS:1561.098 MHz GLONASS:1602.5625 MHz	The frequency of the antenna matches the version of the module.
	Bandwidth	>5 MHz	
	Polarity	RHCP	
	SWR	<1.5	
	Gain	≥2 dBi	
	Efficiency	≥40%	
	Dimensions	15.0×15.0×4.0 mm	
Active antenna	Frequency	GPS:1575.42 MHz BDS:1561.098 MHz GLONASS:1602.0 MHz	The frequency of the antenna matches the version of the module.
	Bandwidth	>6 MHz	
	Polarity	RHCP	
	SWR	<1.5	
	Gain (LNA embedded)	20±2 dB	
	Gain	≥2 dBi	
	Efficiency	≥40%	
	Noise factor	<1.5 dB	
Operating voltage	3.0±0.3 V		

## 5 Electrical Feature and Reliability

This chapter describes the electrical features and reliability of G7A.

### 5.1 Electrical Features

To ensure that G7A functions properly, operate it in recommended operating conditions.

Table 5-1 Extreme operating voltage

Parameter	Description	Minimum Value	Maximum Value	Unit
VBAT	Power supply	-0.3	4.5	V
VDD_IO	Power supply	-0.3	4.5	V
VBACKUP	Backup power supply	-0.3	4.5	V
VIO	IO voltage	-0.3	4.5	V



If the input voltage is lower than the minimum value, the module might fail to start. If the voltage exceeds the high threshold or there is a voltage burst during the startup, the module might be damaged permanently.

Table 5-2 Recommended operating voltage

Parameter	Minimum Value	Typical Value	Maximum Value	Unit
VBAT	2.7	3.3	3.6	V
VDD_IO	2.7	3.3	3.6	V
VBACKUP	1.4	3.3/3.0	3.6	V

Table 5-3 Current features

State		Current	Unit
Continuous position fix	Multi-mode	30	mA
	Single-mode	28	mA
Idle		10	μA

## 5.2 Temperature

Table 5-4 Temperature feature

Module Status	Minimum Value	Typical Value	Maximum Value
Operating	-40°C	25 °C	85°C
Storage	-45°C	/	125°C



If the module works in an environment where the temperature exceeds the thresholds of the operating temperature range, some of its RF performance indicators might be worse but it can still work properly.

## 5.3 ESD Protection

Humidity: 45% Temperature: 25 °C

Table 5-5 ESD feature

Testing Point	Contact Discharge	Air Discharge
VBAT	±8 kV	±15 kV
GND	±8 kV	±15 kV
ANT	±8 kV	±15 kV
Cover	±8 kV	±15 kV
UART	±4 kV	±8 kV
Others	±4 kV	±8 kV

## 6 Mechanical Features

This chapter describes the mechanical features of G7A.

### 6.1 Dimensions

Figure 6-1 G7A dimensions (Unit: mm)

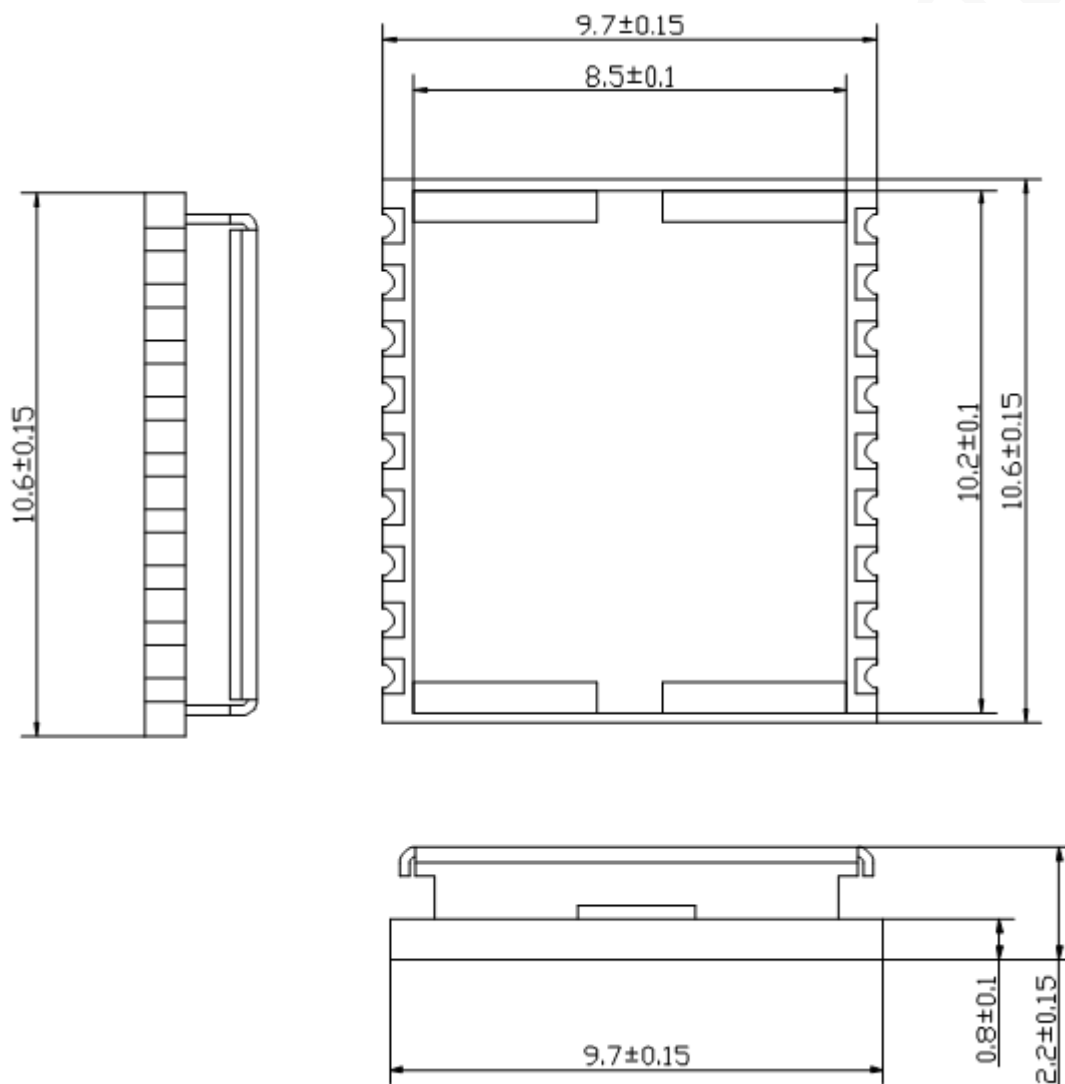

## 6.2 Label

Figure 6-2 and Figure 6-3 shows the label of G7A.

Figure 6-2 G7A-B1 label



Figure 6-3 G7A-D1 label



## 6.3 Packaging

G7A modules are packed in sealed bags on delivery to guarantee a long shelf life. Follow the same package of the modules again in case of opened for any reasons.

### 6.3.1 Tape & Reel Packaging

G7A in mass production are shipped in the following package.

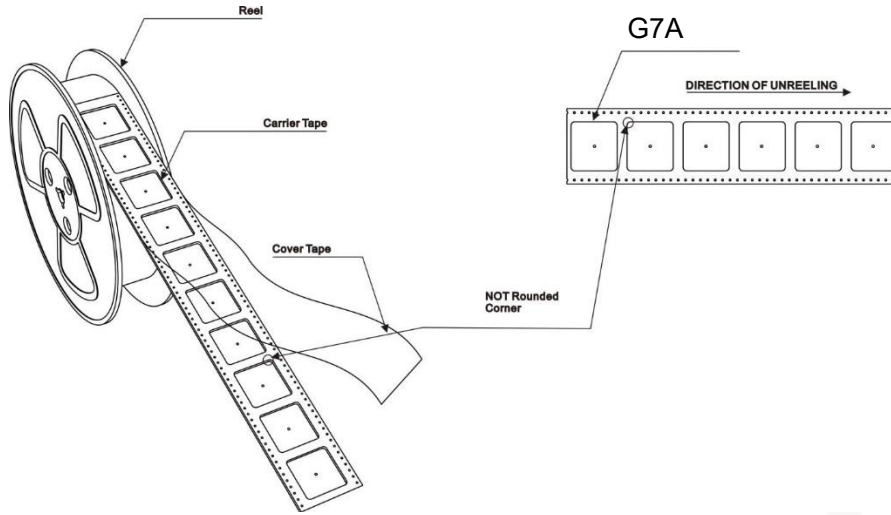

Tape

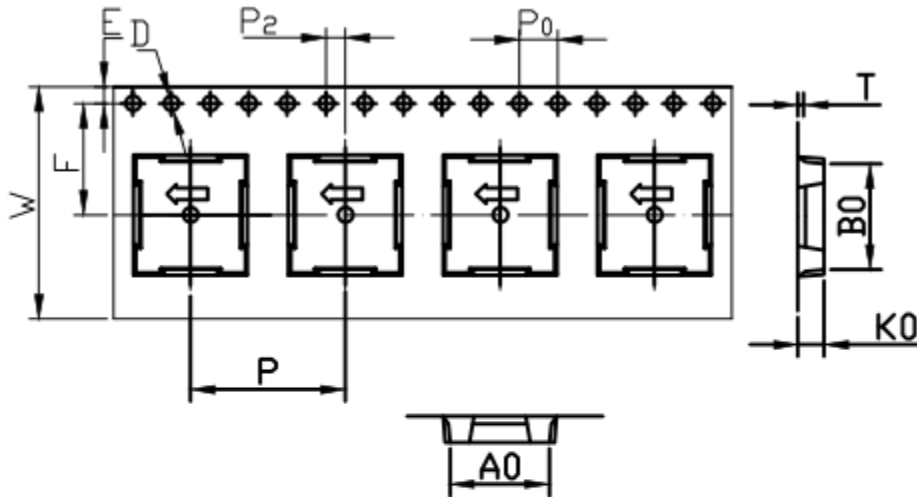

ITEM	W	A <sub>0</sub>	B <sub>0</sub>	K <sub>0</sub>	K <sub>1</sub>	P	F	E	D	D <sub>1</sub>	P <sub>0</sub>	P <sub>2</sub>
DIM	24.0 <sup>+0.30</sup> <sub>-0.10</sub>	10.1 <sup>+0.10</sup> <sub>-0.10</sub>	11.0 <sup>+0.10</sup> <sub>-0.10</sub>	2.7 <sup>+0.10</sup> <sub>-0.10</sub>	0.00 <sup>+0.10</sup> <sub>-0.10</sub>	16.0 <sup>+0.10</sup> <sub>-0.10</sub>	11.5 <sup>+0.10</sup> <sub>-0.10</sub>	1.75 <sup>+0.10</sup> <sub>-0.10</sub>	1.50 <sup>+0.10</sup> <sub>-0.00</sub>	0.00 <sup>+0.25</sup> <sub>-0.00</sub>	4.00 <sup>+0.10</sup> <sub>-0.10</sub>	2.00 <sup>+0.10</sup> <sub>-0.10</sub>

Reel

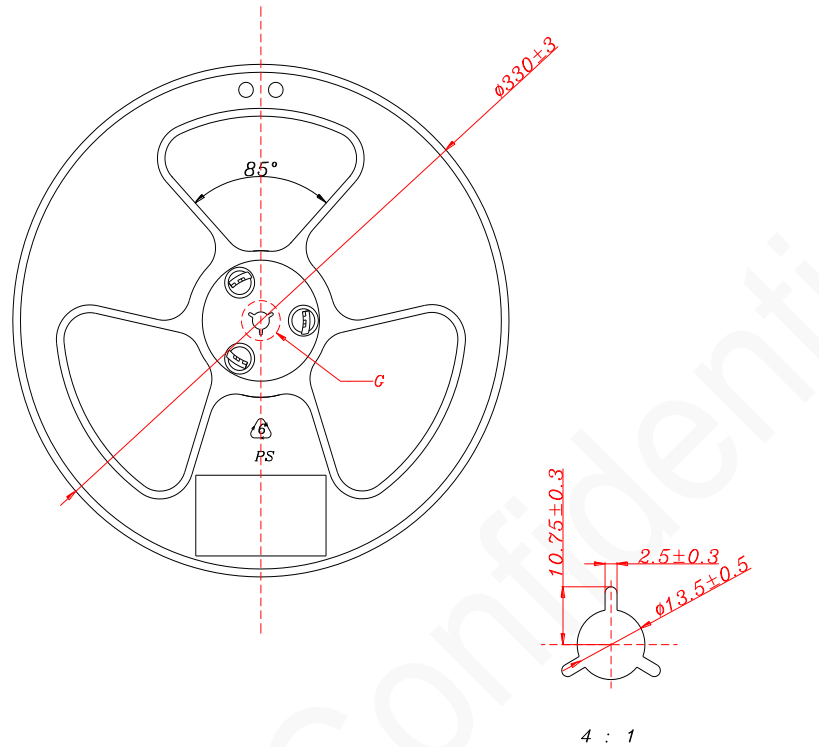

### 6.3.2 Moisture-Sensitive

G7A is a level 3 moisture-sensitive electronic elements, in compliance with IPC/JEDEC J-STD-020 standard.

If the module is exposed to air for more than 48 hours at conditions not worse than 30°C/60% RH, bake it at a temperature higher than 90 degree for more than 12 hours before SMT. Or, if the indication card shows humidity greater than 20%, the baking procedure is also required. Do not bake modules with the package tray directly.

## 7 Application Design and SMT

G7A is introduced in LCC package. This chapter provides G7A foot print, recommended PCB design and SMT information to guide users how to mount the module onto application PCB board.

### 7.1 G7A Foot Print

Figure 7-1 G7A foot print (bottom view)

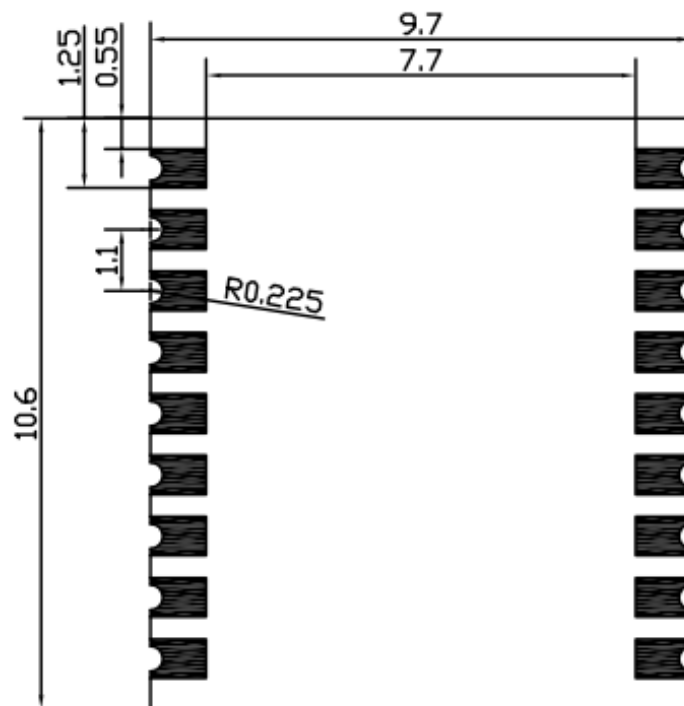

### 7.2 Recommended Footprint

错误!未找到引用源。 shows the recommended application PCB footprint. (Unit: mm)

Figure 7-2 Recommended PCB footprint (top view)

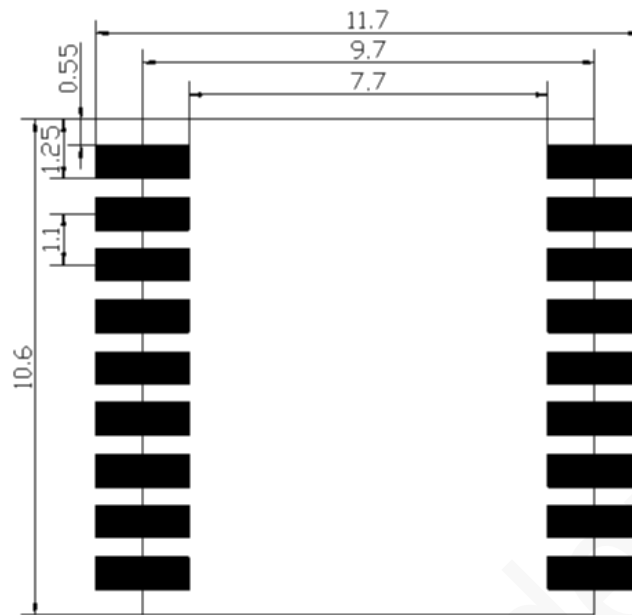

## 7.3 Stencil

The recommended stencil thickness is at least 0.12 mm to 0.15 mm.

## 7.4 Solder Paste

Do not use a kind of solder paste different from our module technique.

- The melting temperature of solder paste with lead is 35°C lower than that of solder paste without lead. It is easy to cause faulty joints for LCC inside the module after second reflow soldering.
- When using only solder pastes with lead, please ensure that the reflow temperature is kept at 220°C for more than 45 seconds and the peak temperature reaches 240°C.

## 7.5 Reflow Profile

G7A is compatible with industrial standard reflow profile for lead-free SMT process.

The reflow profile is process dependent, so the following recommendation is just a start point guideline:

- Only one flow is supported.

- Quality of the solder joint depends on the solder paste volume. Minimum of 0.12 mm to 0.15 stencil thickness is recommended.
- Use bigger aperture size of the stencil than actual pad size.
- Use a low-residue, no-clean type solder paste.

Figure 7-3 Temperature curve

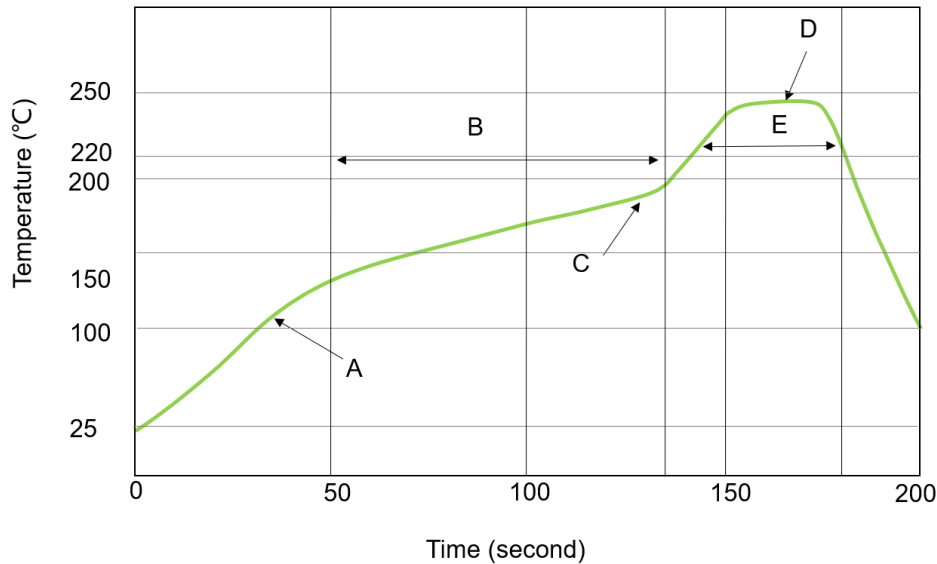

X: Time (s) Y: Temperature (°C)

Technical parameters:

- Ramp up rate: 1 to 4°C/sec
- Ramp down rate: -3 to -1°C/sec
- Soaking zone: 150-180°C for 60-100 seconds
- Reflow zone: >220°C for 40-90 seconds
- Peak temperature: 235-245°C



Neoway will not provide warranty for heat-responsive element abnormalities caused by improper temperature control.

For information about cautions in G7A storage and mounting, refer to *Neoway Module Reflow Manufacturing Recommendations*.

To maintain and manually desolder it, use heat guns with great opening, adjust the temperature to 245 degrees (depending on the type of the solder paste), and heat the module till the solder paste is melt. Use tweezers to remove the module. Do not shake the module in high temperature while removing it. Otherwise, the components inside the module might be misplaced.

## 8 Safety Recommendations

Ensure that this product is used in compliant with the requirements of the country and the environment. Please read the following safety recommendations to avoid body hurts or damages of product or work place:

- Do not use this product at any places with a risk of fire or explosion such as gasoline stations, oil refineries, etc
- Do not use this product in environments such as hospital or airplane where it might interfere with other electronic equipment.

Please follow the requirements below in application design:

- Do not disassemble the module without permission from Neoway. Otherwise, we are entitled to refuse to provide further warranty.
- Please design your application correctly by referring to the HW design guide document and our review feedback on your PCB design.
- Please avoid touch the pins of the module directly in case of damages caused by ESD.

## A Abbreviation

Abbr	Full Name
AGPS	Assisted GPS
CEP	Circular Error Probable
DGPS	Differential GPS
EASY	Embedded Assist System
EGNOS	European Geostationary Navigation Overlay Service
EPO	Extended Prediction Orbit
EMI	Electro Magnetic Interference
ESD	Electronic Static Discharge
GPS	Global Positioning System
GNSS	Global Navigation Satellite System
GGA	GPS Fix Data
GLONASS	Global Navigation Satellite System
GSV	GNSS Satellites in View
I/O	Input/output
LNA	Low Noise Amplifier
MSAS	Multi-Functional Satellite Augmentation System
NMEA	National Marine Electronics Association
PPS	Pulse Per Second
PRN	Pseudo Random Noise Code
QZSS	Quasi-Zenith Satellite System
RHCP	Right Hand Circular Polarization
RMC	Recommended Minimum Specific GNSS Data
SBAS	Satellite-based Augmentation System
SAW	Surface Acoustic Wave
TTFF	Time To First Fix
UART	Universal Asynchronous Receiver & Transmitter