



PL-6050PGF

CELLULAR/LTE, 2.4/5.0 GHz ISM and GNSS Adhesive Mount

Key Features

Cable 1: CELLULAR / LTE

- 698-960 MHz
- 1710-2170 MHz
- 2500-2700 MHz

Cable 2: 2.4/5.0 GHz ISM

- 2410-2490 MHz
- 4920-5925 MHz

Cable 3: GPS/GLONASS/QZSS/Galileo

- 1575-1606 MHz

Adhesive Mount

Ground Plane Independent

Customizable Cable and Connector

Dimensions: 80 x 76 x 16 mm



1. Antenna Description

PL-6050PGF “The Falcon Series”

A Remarkable All-Inclusive Antenna Solution

When it comes to choosing the most competitive and versatile antenna solution, the Falcon Series is at the top of its class. This uniquely designed PL-6050PGF Falcon Antenna is built to enable compatibility with different communication standards and a variety of technologies offering the architecture of a 3-in-1, 2-in-1 and also 1-in-1 configurations.

The outstanding feature of this multi-versatile antenna is that it has a unique, sleek and compact design with a maximum height of 15 mm. This allows for a turnkey implementation of NB-IoT, CAT-M devices to be used in applications such as environmental monitoring, waste management, fleet tracking and other multitudes of systems. This solution combines the advantages of low profile, low cost and massive deployment operations. Several mounting options such as adhesive, magnetic, screw and magnetic/adhesive make the installation of this antenna extremely convenient.

High Rejection GNSS Filter Technology

The Global Navigation Satellite System is a modernized technology denoting satellite navigation systems that provide autonomous geo-spatial positioning with global coverage. To keep up with its latest technological refinement, the 2JP6050PGF Falcon Antenna offers a high rejection GNSS filter technology in a compact design, enabling it to handle reception when collocated along other antennas in the same enclosure such as LTE or WiFi standards, allowing the absorption and protection undesired against out-of-band signals. The low noise figure helps to maintain excellent signal quality providing signal attenuation without impacting in-band signal quality.

Typical applications

- Infotainment systems
- WiFi hotspot
- HD video transmission
- Dash cameras
- Connected cars
- Self-driving cars
- Fleet management
- Gateways
- Routers
- Public transportation
- Logistics
- And others

Compatibility Standards

LTE Cables

- CAT 1 2 3 4 5 6 7 8 9 10 11 12
- NB-IoT, LTE-NB1, CAT-M1, CAT-M2
- WCDMA, UMTS, HSPA, EDGE GRPS, GSM, CDMA

2.4/5.0 Cables

- WiFi, Bluetooth, BLE, ISM
- DSRC, V2V, V2X
- Sigfox, LoRa, ZigBee, RPMA, LPWAN

GPS/GLO Cable

- GPS, GLONASS
- Galileo, QZSS, L1, E1

Installation and Safety Profile

A double adhesive pad is provided for rapid installation on any surface locations such as glass windshields, plastic or any other nonmetal area with ease. Among the different mounting options, this package is fully customizable with variable cable lengths and connector types. It also includes a standard RF cable or low loss cable for better reception and range. Where durability is concerned, the Falcon antenna series retains a IP67 protection rating guaranteeing total protection against dust and water immersion of up to 1-meter depth.

Where projects require a highly durable antenna for extensive outdoor use, this series features a high-grade UV stable plastic that protects it from ultraviolet rays deterioration.

Standout Features

- Antenna 3-in-1 compatible with LTE, Wifi and GNSS devices
- Worldwide Utility LTE/4G/3G/2G
- 15 mm max height profile
- Different mounting options available
- High rejection GNSS filter technology in compact collocated design
- GNSS capability for GPS, Glonass, Galileo, and QZSS
- Patented GNSS low power consumption and low noise figure
- Enhanced geolocation and precise tracking

2. Antenna and electrical specifications

Cable 1

Parameters	CELLULAR / LTE Antenna		
Standards	2G,3G and 4G		
Band (MHz)	700/850/900	1700/1800/1900/2100	2600
Frequency (MHz)	698-960	1710-2170	2500-2700
Return Loss (dB)	~-9.7	~-21.5	~-8.8
VSWR	~2.2:1	~1.2:1	~2.2:1
Efficiency (%)	~55.6	~56.0	~38.7
Peak Gain (dBi)	~-2.9	~-3.2	~-2.1
Average Gain (dB)	~-2.6	~-2.5	~-4.1
Impedance (Ohm)	50		
Polarisation	Linear		
Radiation Pattern	Omni-Directional		
Max. Input Power (W)	25		
Connector Type	SMA-Male Standard (Other Connectors Available)		
Cable Length	300 cm Standard (Any Cable Length Available)		
Cable Type	LMR100 Standard (Other Cables Available)		

Cable 2

Parameters	2.4/5.0 GHz ISM Antenna	
Standards	WiFi, BT, ZigBee, ISM	
Band (MHz)	2.4 GHz	5.0 GHz
Frequency (MHz)	2410-2490	4920-5925
Return Loss (dB)	~-19.8	~-18.1
VSWR	~1.3:1	~1.3:1
Efficiency (%)	~50	~30
Peak Gain (dBi)	~-3.2	~-4.2
Average Gain (dB)	~-3.0	~-5.4
Impedance (Ohm)	50	
Polarisation	Linear	
Radiation Pattern	Omni-Directional	
Max. Input Power (W)	25	
Connector Type	RP-SMA-Male Standard (Other Connectors Available)	
Cable Length	300 cm Standard (Any Cable Length Available)	
Cable Type	LMR100 Standard (Other Cables Available)	

Antenna Measurement Conditions:

Mounted on 30 x 30 x 0.25 cm ABS Plate

200 cm of Cable LMR100

Measured in Certified CTIA 3D Anechoic Chamber

Cable 3

Parameters	GPS/GLONASS Antenna	
	GPS/QZSS/Galileo	GLONASS
Standard		
Band (MHz)	1575	1602
Frequency(MHz)	1575.42	1598-1606
Patch Size (mm)	25 x 25 x 4	
Return Loss (dB)	<=-15.0 dB	
VSWR	<=1.4:1 dB	
Impedance	50	
Radiation Pattern	Hemispherical	
Polarization	RHCP	
Saw Filter	Pre-filter	
Active Gain (dB)	28 @ 2.7 V	
Noise Figure (dB)	1.5 Typ	
Voltage (V)	1.5 – 3.6	
Current (mA)	9 Typ	
Power Consumption (mW)	24.3 Typ	
ESD Protection (kV)	2kV	
Connector Type	SMA-Male Standard (Other Connectors Available)	
Cable Length	300 cm Standard (Any Cable Length Available)	
Cable Type	LMR100 Standard (Other Cables Available)	

3. Mechanical and environmental specifications

Specifications	PL6050PGF
Mounting Type	Adhesive Mount
Dimensions (mm)	80 x 76 x 16
Radome Type	ABS UV Stable
Radome Color	Black or White
Operating Temperature (C)	-40 to +85
Storage Temperature (C)	-40 to +85
Substance Compliance	RoHS

4. Antenna parameters

Table 1: CELLULAR/LTE

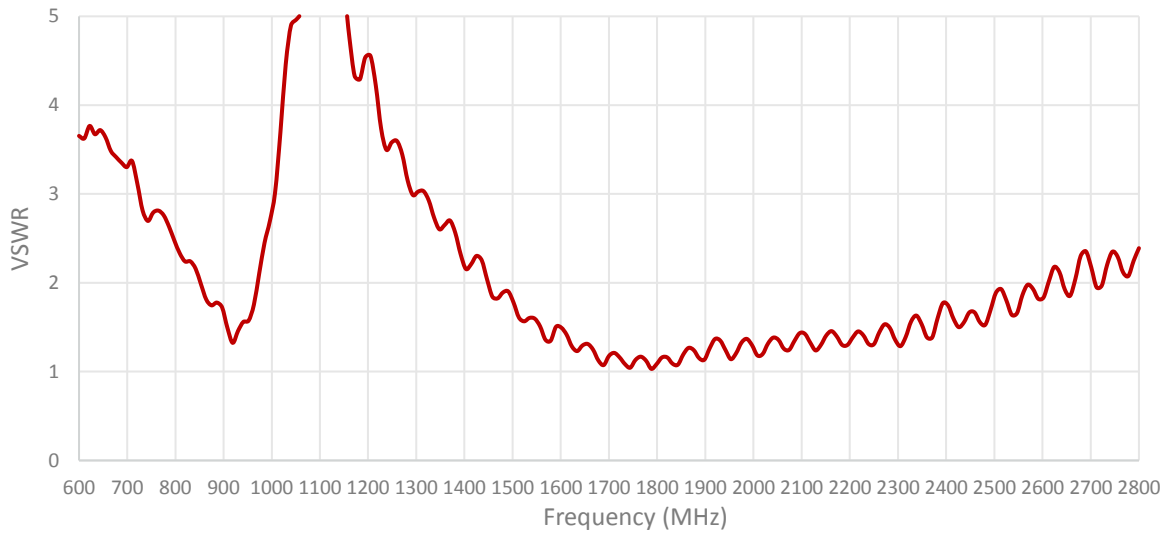
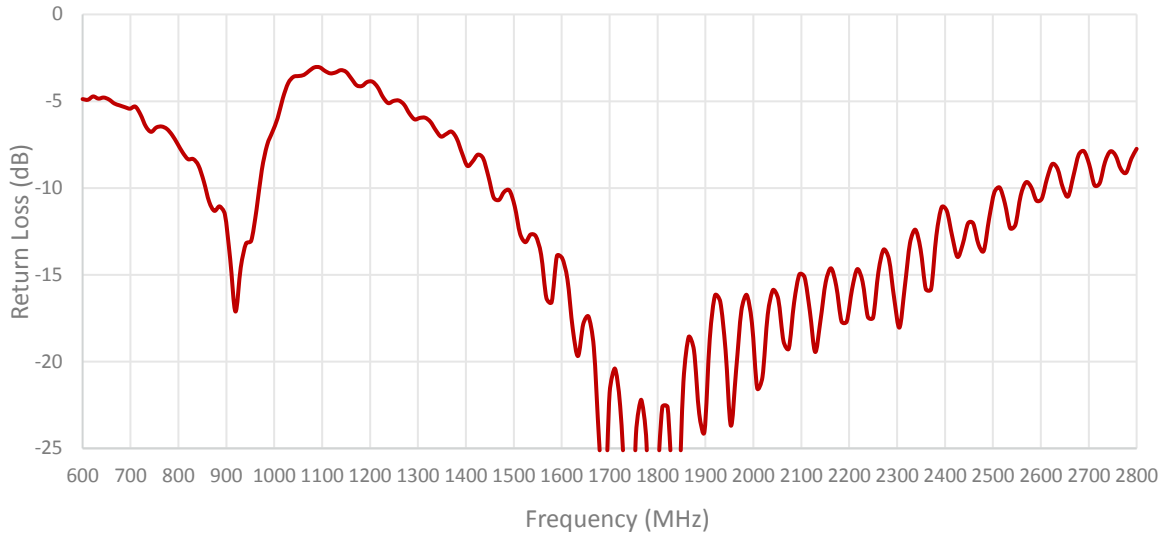

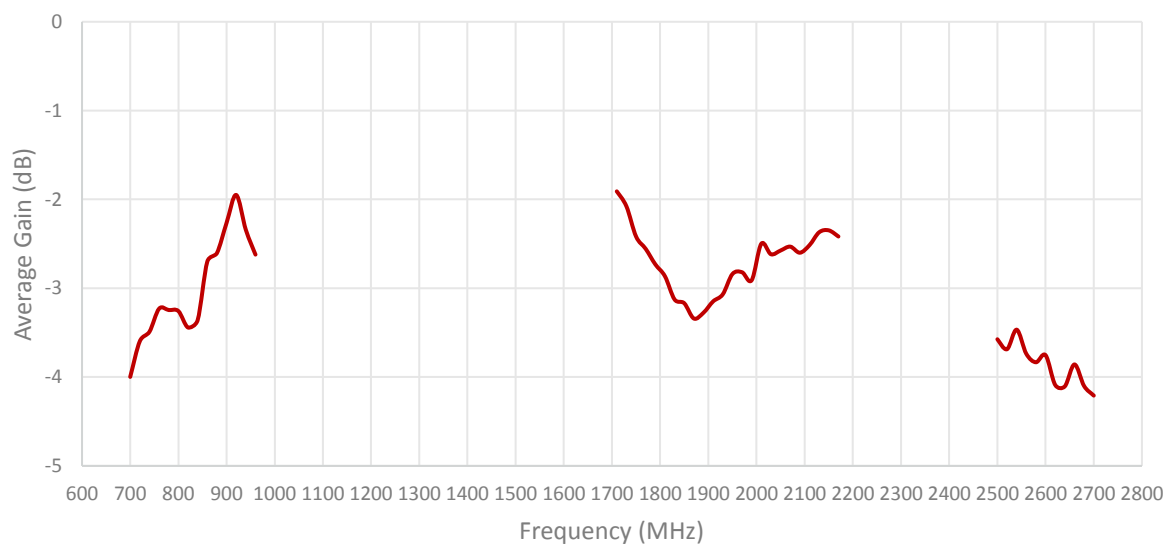
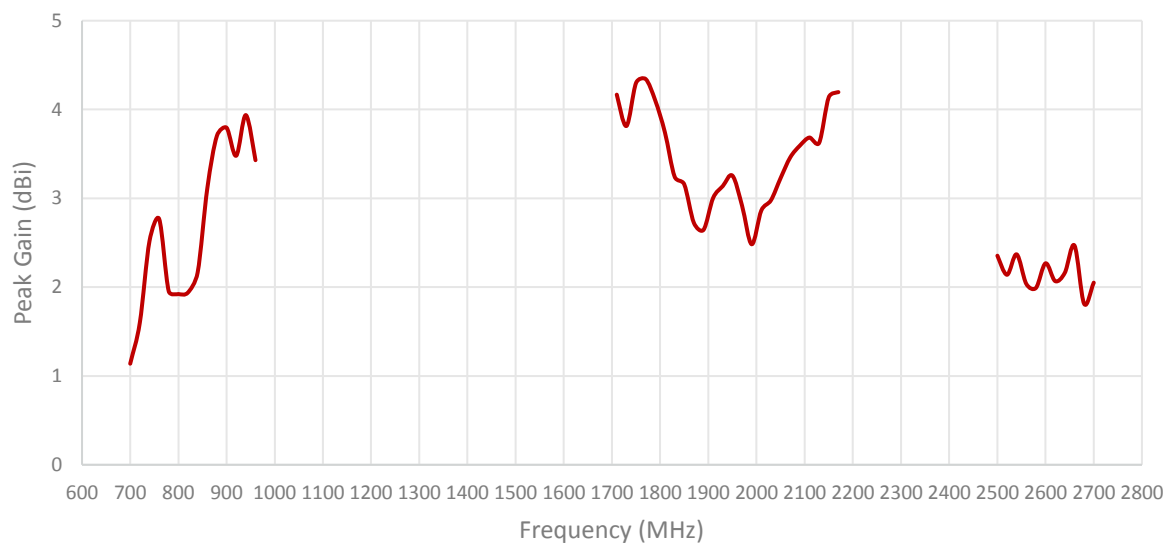
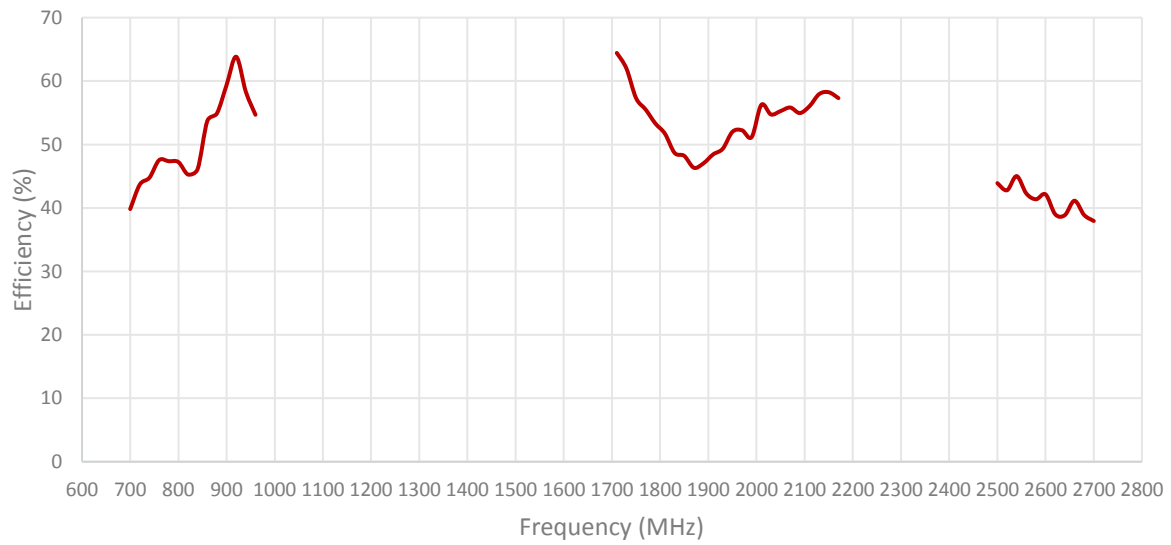

Cable 2: 2.4/5.0 GHz ISM

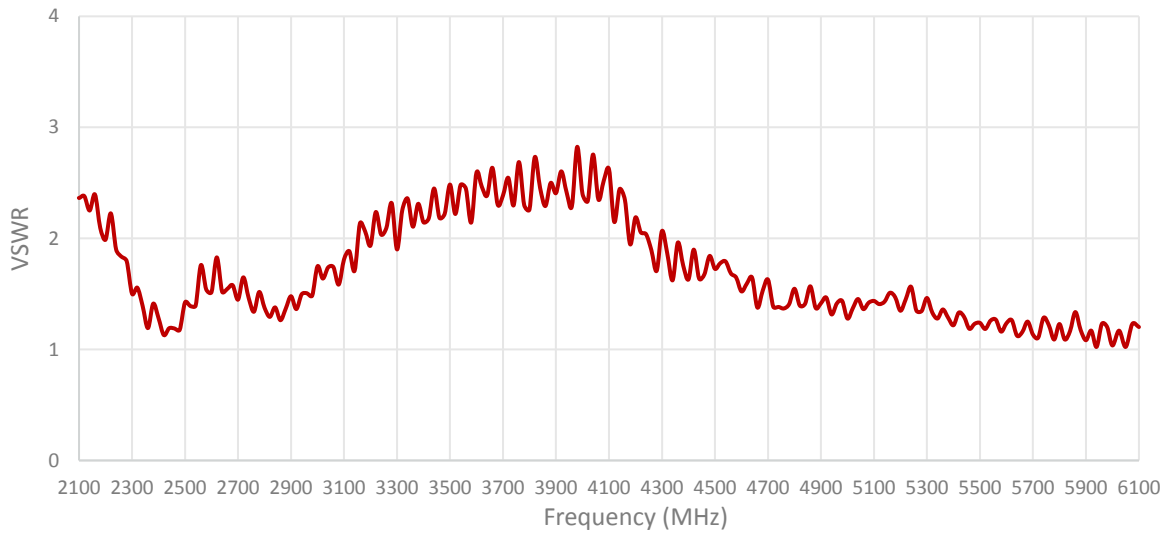
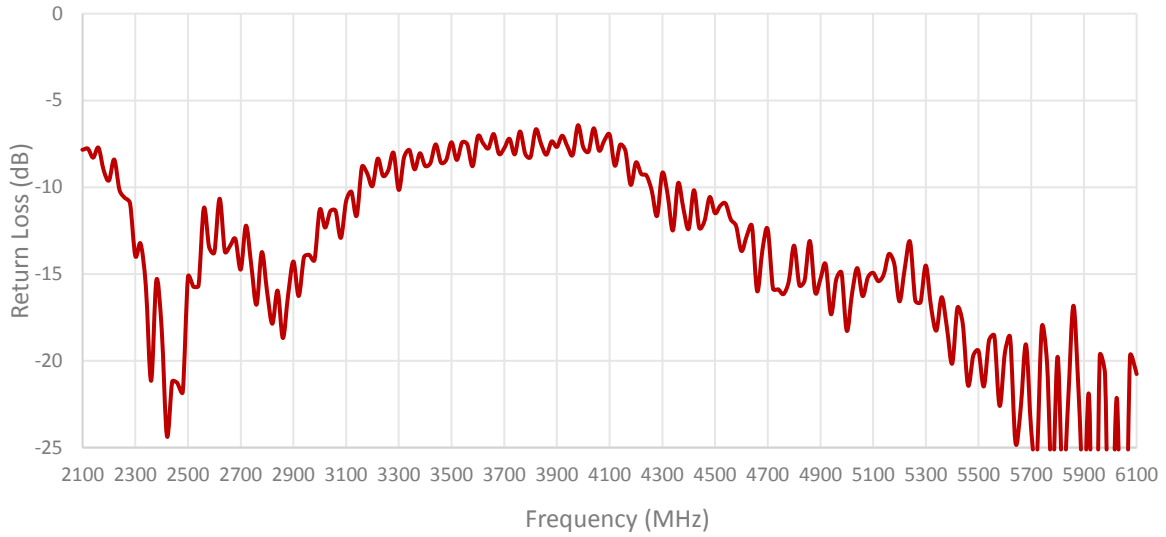

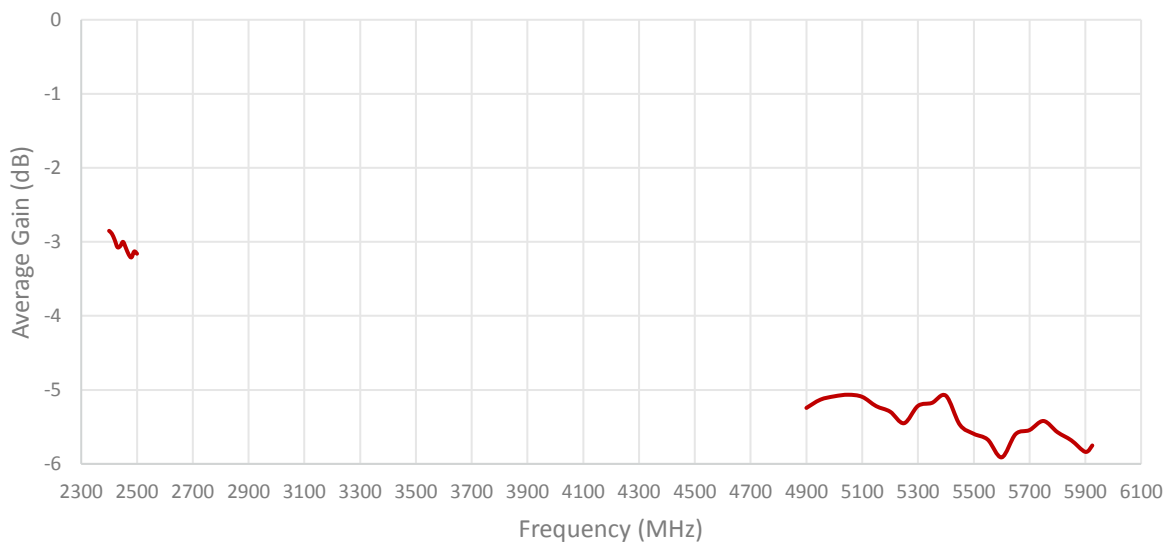
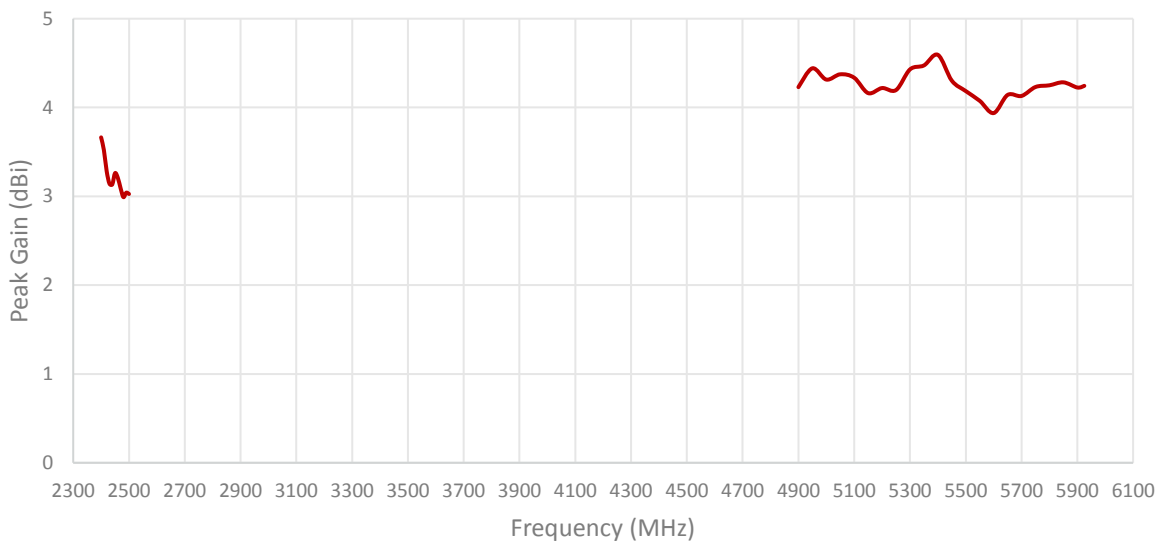
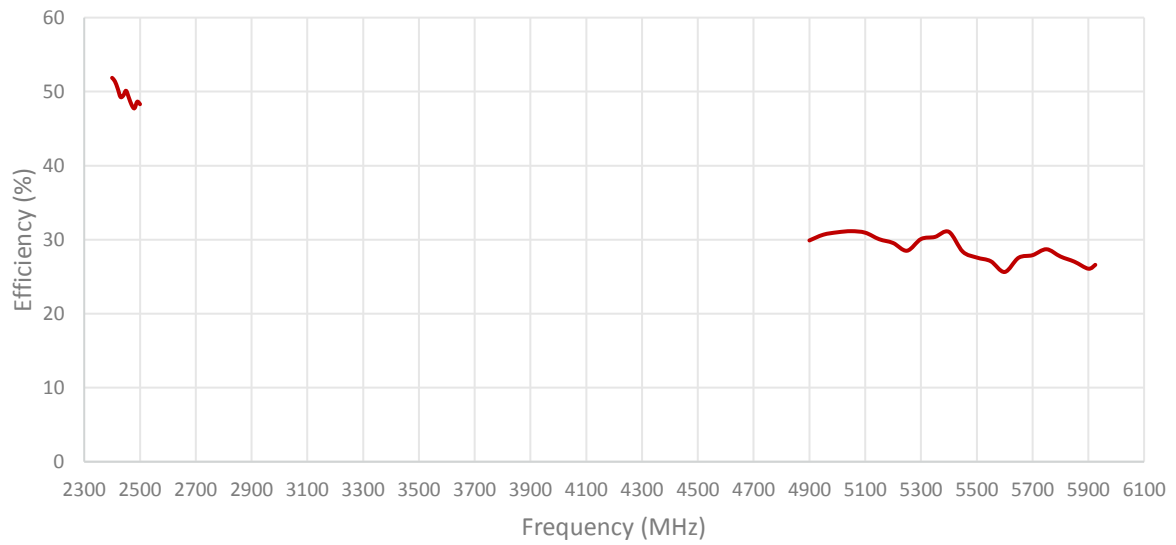

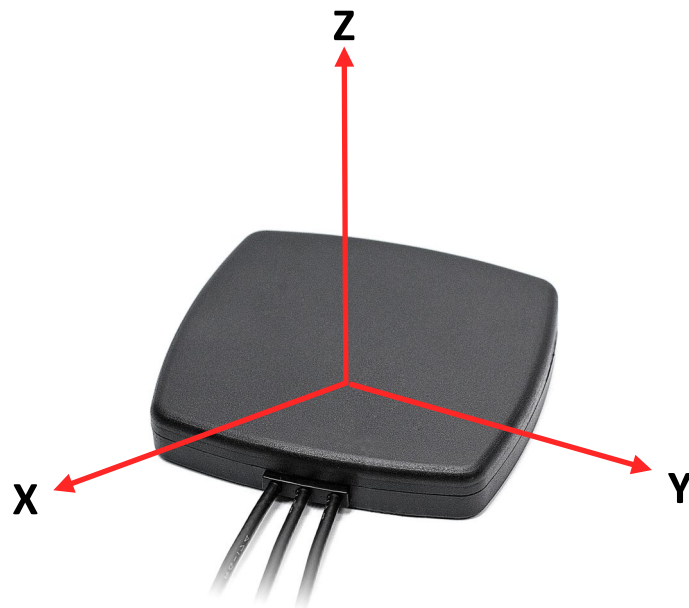

Radiation pattern reference

Table 1: CELLULAR/LTE

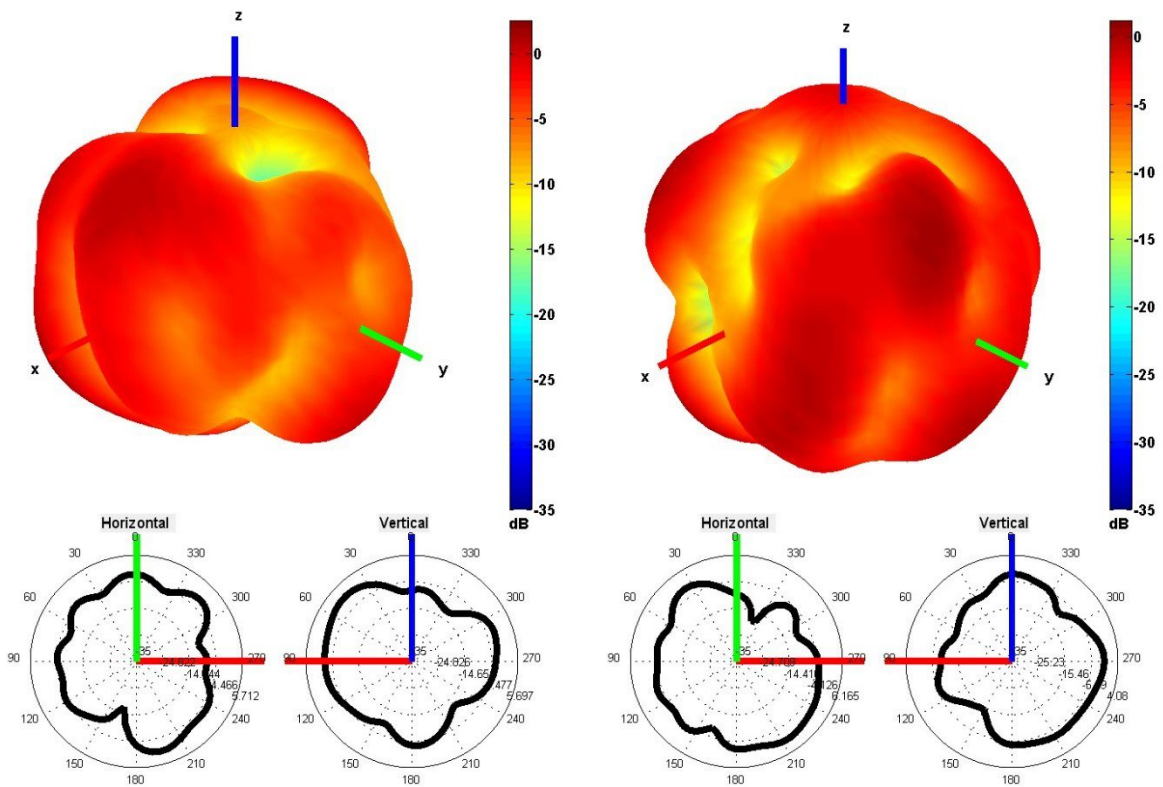

750 and 850 MHz Radiation pattern

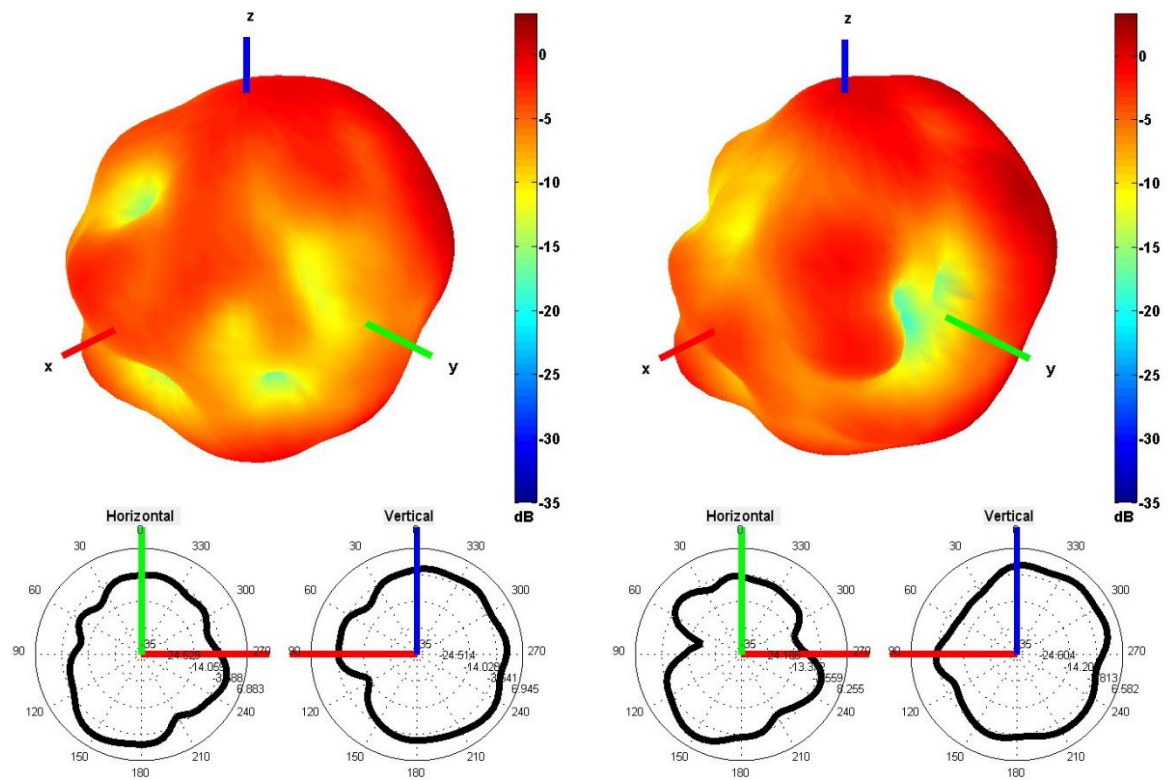
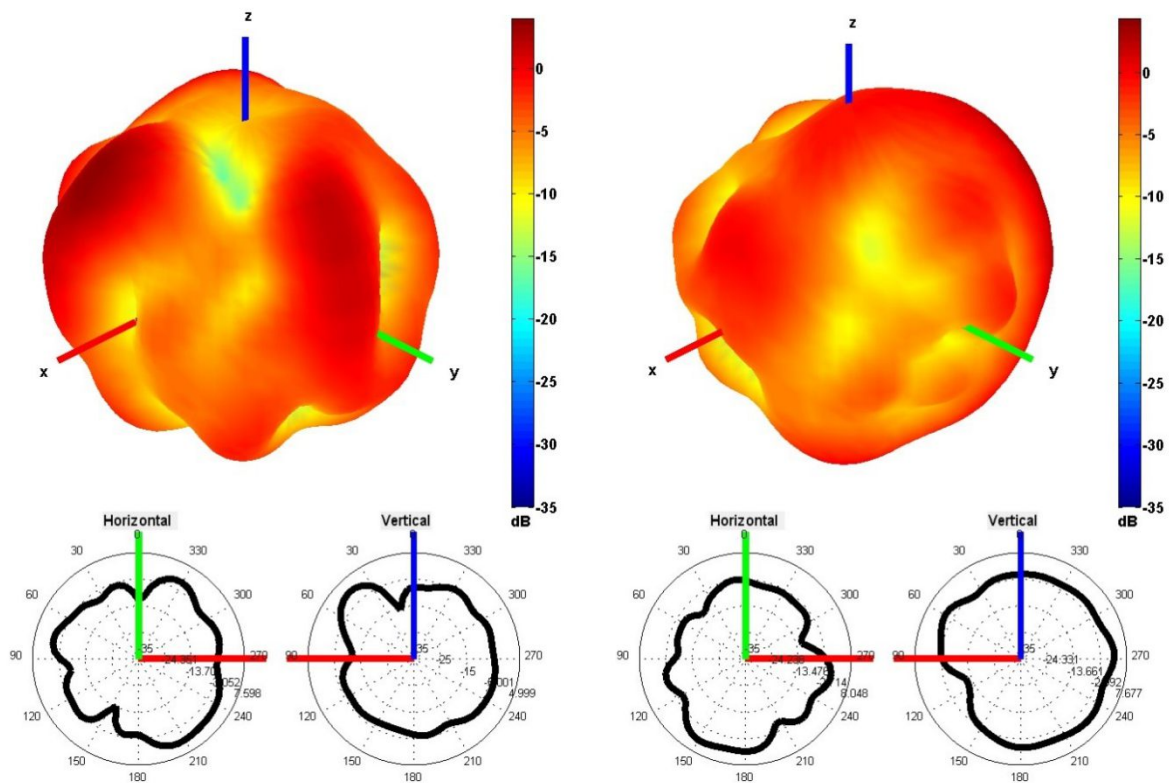

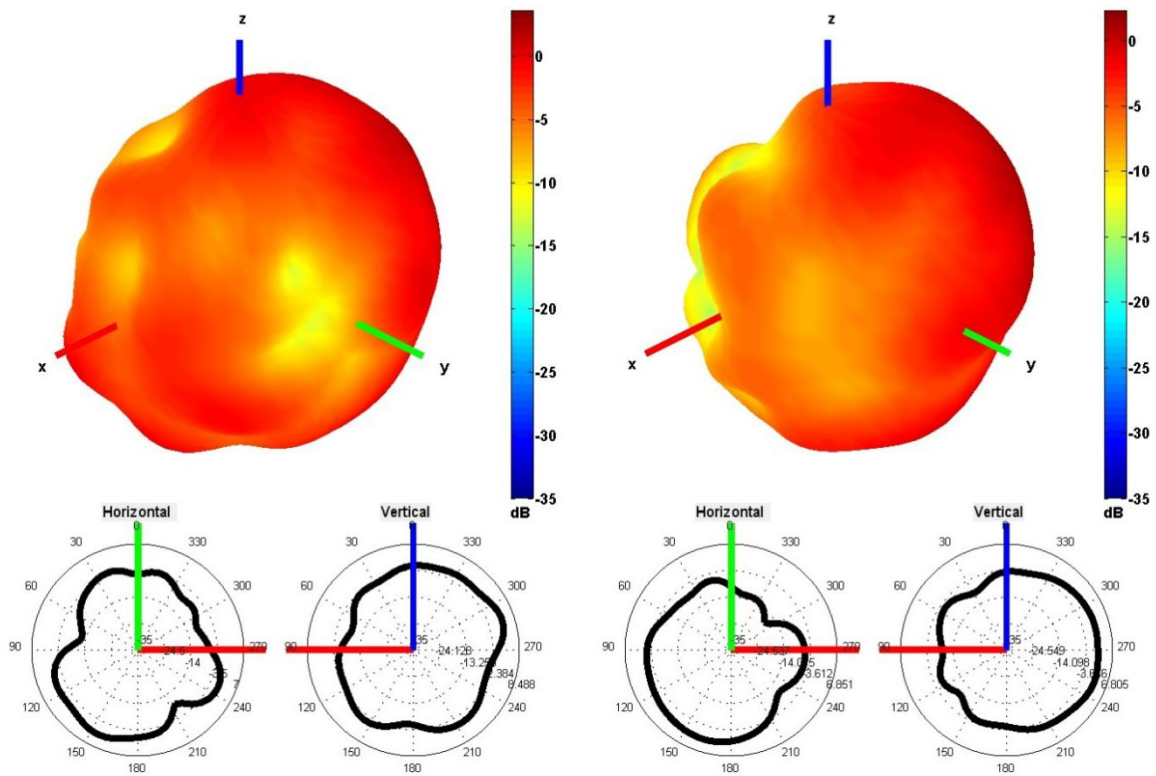

2100 and 2600 MHz Radiation pattern

Table 2: 2.4/5.0 GHz ISM

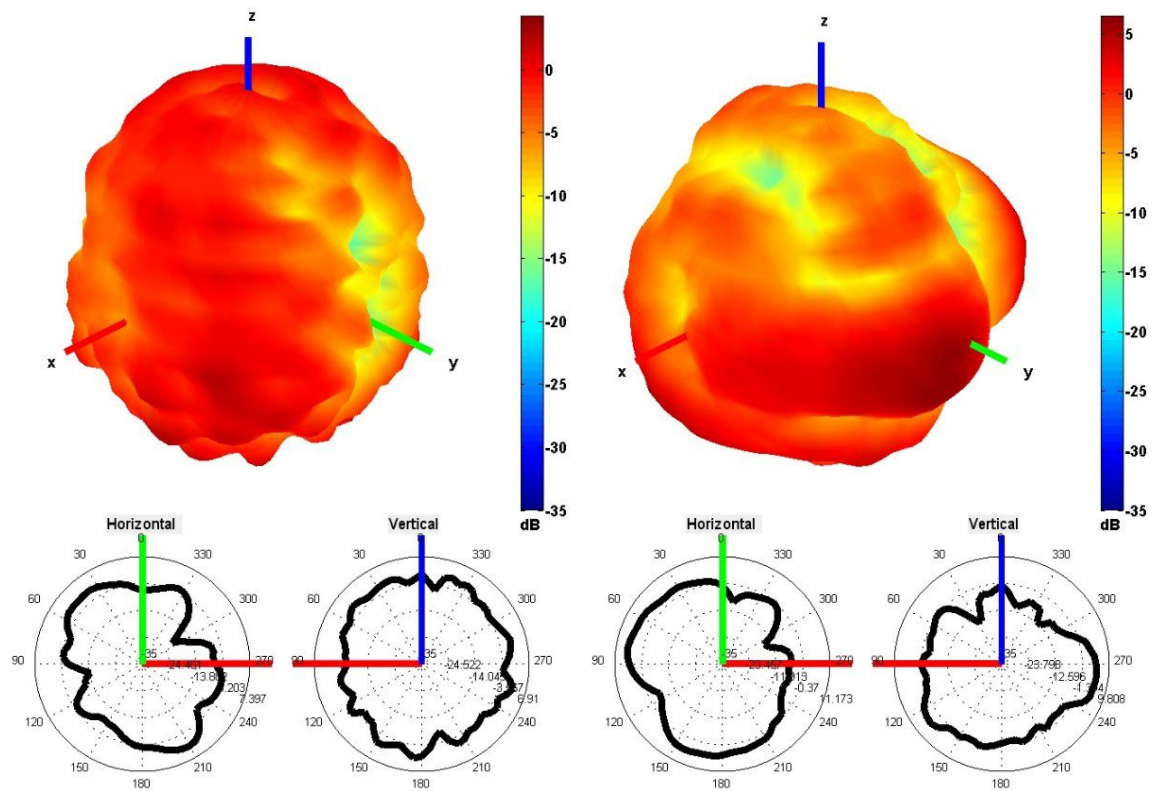

2450 and 5500 MHz Radiation pattern

5. Antenna drawings

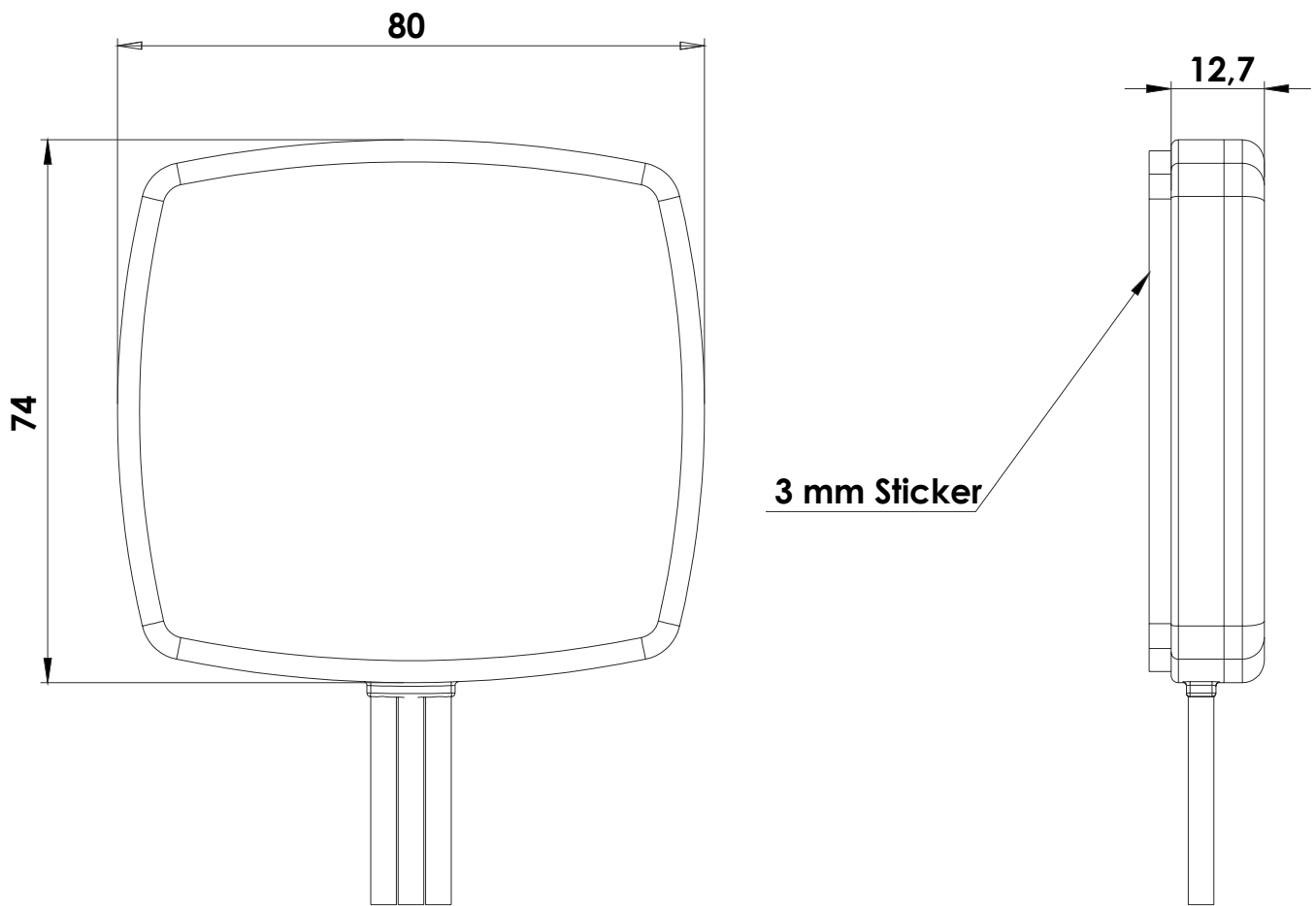

6. Antenna Images

